

# Data Sheet TMxCore

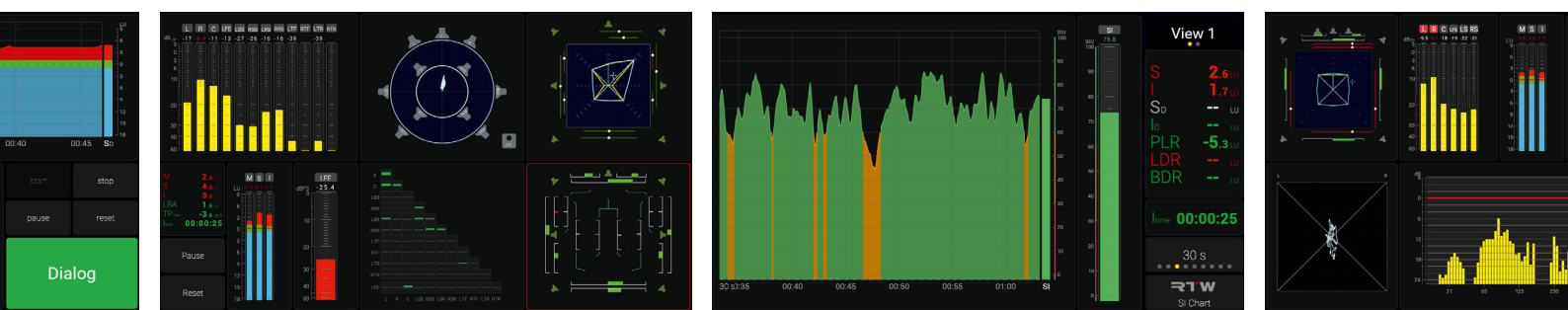

# TMxCore



**High-end • External Screen • DisplayPort • Flexible Screen Layout • 32 AoIP Channels: Dante® or RAVENNA® • Immersive 16 Classic I/O Channels • RTW Loudness & Metering Suite • Speech Intelligibility • Network Display • Chart • Vectorscope • RTA**

TMxCore is ideal for installations where performance, integration, and flexibility are key. It supports AI-driven tools like speech intelligibility metering and immersive audio analysis, while Network Display enables real-time metering in any standard web browser for remote monitoring or multi-screen setups. TMxCore can be integrated

either into Dante® resp. RAVENNA®/AES67/ST 2110 AoIP networks or into digital environments. With DisplayPort output for connection to any monitor and its full compatibility with RTW's renowned loudness and metering suite, the TMxCore offers maximum precision, adaptability, and reliability.

## Graphical User Interface

The TMxCore's graphical user interface is controlled simply by a mouse or the touch of your finger, depending on whether a standard monitor or a touch display is used for viewing. The integrated instruments can be scaled, randomly positioned and combined for optimum utilization

of the available screen space.

TMxCore can be customized to suit individual needs directly on the device via the monitor or via the IP address, a web browser, and a comprehensive web app within the network.

# The Device

## Hardware

- High-end, high-performance broadcast and pro audio metering platform
- Network-ready with RAVENNA®, AES67, ST 2110, Dante®, and AES I/O options
- 12 - 24 V DC power supply
- DisplayPort output for direct connection to any monitor
- Operation and device configuration via mouse or touch depending on connected monitor or display
- Dedicated network connection (LAN) for optimal configuration via WebApp or licensed use of Network Display and for control (OSC)
- Compact device in tabletop housing, can be mounted in a variety of ways using various 1/4" threads on the sides
- 19" rack mounting possible using the supplied, optionally screw-on brackets

## Software

- Extensive menu for system settings and creating presets
- Up to 31 presets selectable
- Applications and instruments freely scalable and positionable using View Editor
- Comprehensive suite with classic and new loudness and metering instruments
- Expandable with optional licenses:
  - SW23010: Immersive audio metering for Surround and Immersive formats including 5.1 and 7.1.4 with Immersive Sound Analyzer, Matrix Correlator, Multi Correlator and Polarscope
  - SW23020: AI-assisted Speech Intelligibility meter for advanced speech intelligibility analysis
  - SW2303n: Network Display: Up to 3 network displays of the measured values can be accessed in any connected browser

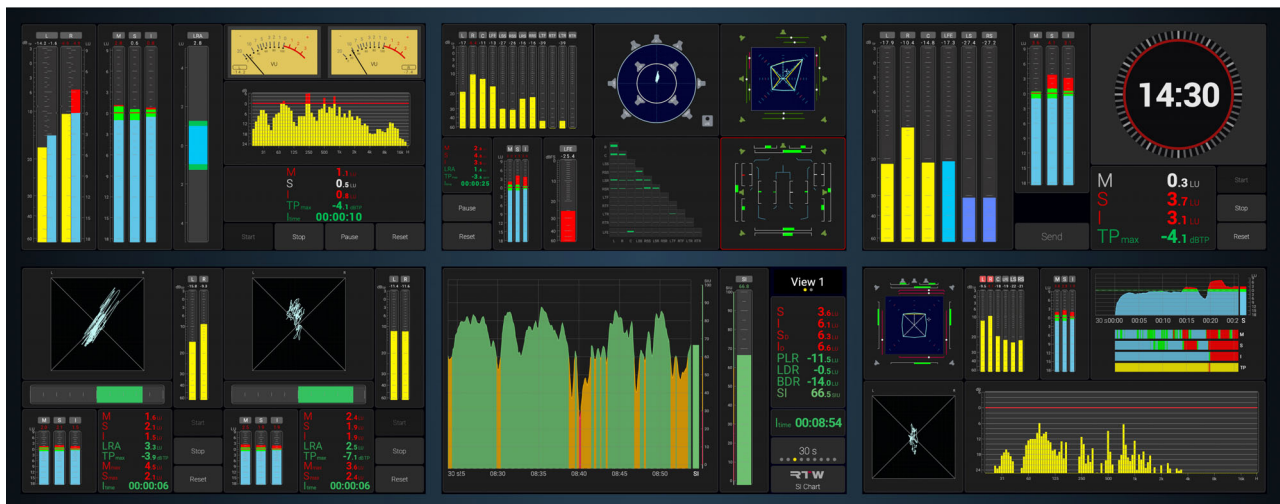

# The Modells

The TMxCore was developed specifically for Audio over IP environments and supports the Dante®, RAVENNA®, AES67, and ST 2110 protocols. However, there are also a variant with AES3. A dedicated network connection for control, separates audio and control traffic, ensuring stability and security.

## Network-enabled models for AoIP

### 230017NR – Dante® 32

32-channel audio interface with:

- 32 Dante® AoIP network channels (2 x RJ-45, Primary/Secondary)



### 230018NR – RAVENNA® 32

32-channel audio interface with:

- 32 RAVENNA®/AES67/ST 2110 AoIP network channels (2 x RJ-45, Primary/Secondary)



### 230013NR – Digital 16

16-channel audio interface with:

- 16-channel digital in- and outputs (transformer balanced, 110 Ohm, 8 x AES3 In/8 x AES3 Out, D-Sub)



# The Software

TMxCore is a high-performance platform that, in addition to its control functions, offers a comprehensive software package of proven and new metering and audio analysis tools with a wide range of settings options. Depending on the model, up to 16 or 32 input channels can be processed.

In addition to its compact design, the software equipment enables use in professional measurement environments where performance, integration, and flexibility are paramount. Additional instruments are available for special applications, which can be activated by purchasing and activating licenses.

## Software Equipment

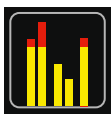

PPM

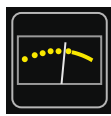

Moving Coil



Stereo Correlator

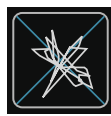

Audio Vectorscope

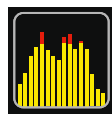

Realtime Analyzer



Chart



Label



Clock



Loudness Sum



Numeric

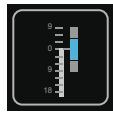

Loudness Range (LRA)



Ratio



LFE Bleed



Dialog Detector



Action Instrument & Open Sound Control

## Software Licenses

Software licenses can be ordered either together with the order or at a later point in time.

Together with the order the license will be activated at delivery.

When a license is needed at a later point in time, a device-specific file for forwarding to RTW is created by the unit during the order process. RTW will send back a corresponding file with the activated license for exactly this unit.

### SW23010: Surround & Immersive Instruments



Expansion with instruments for immersive measurements that reflect what we hear: Immersive Sound Analyzer, Matrix Correlator, Multi Correlator and Polarscope

### SW23020: Speech Intelligibility Instruments



Speech Intelligibility (SI) Meter for AI-assisted, objective measurement of speech intelligibility

### SW23030: Network Display: Add. Screen 1

Additional virtual screen for real-time audio measurements in the local network without additional hardware

### SW23031: Network Display: Add. Screen 2

Second additional virtual screen for real-time audio measurements in the local network without additional hardware

--- Precondition: SW23030 ---

### SW23032: Network Display: Add. Screen 3

Third additional virtual screen for real-time audio measurements in the local network without additional hardware

--- Precondition: SW23030 and SW23031 ---



# Dimensions

**TMxCore** (230011NR/230013NR/230017NR/230018NR)

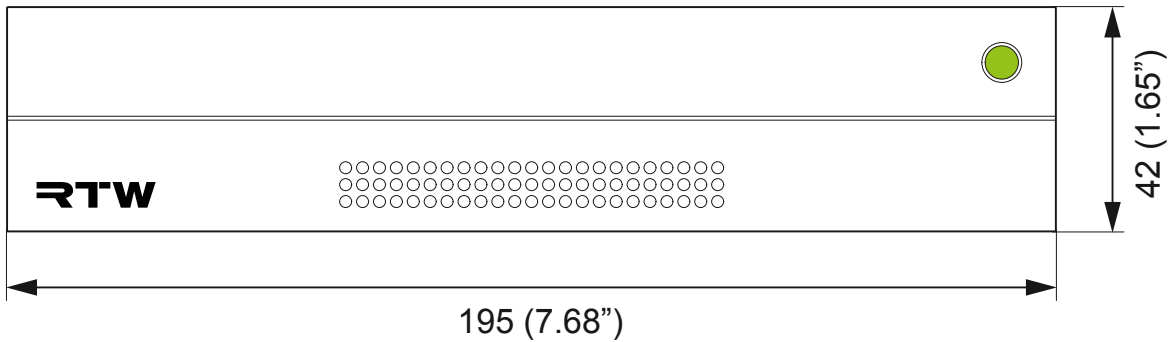

1 | Front view | dimensions in mm (inch)

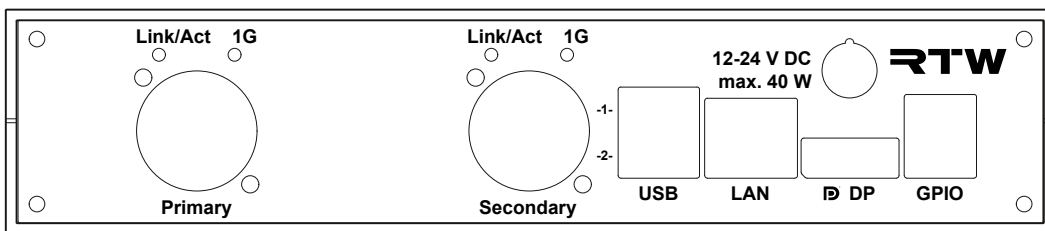

2 | Rear view | dimensions in mm (inch)

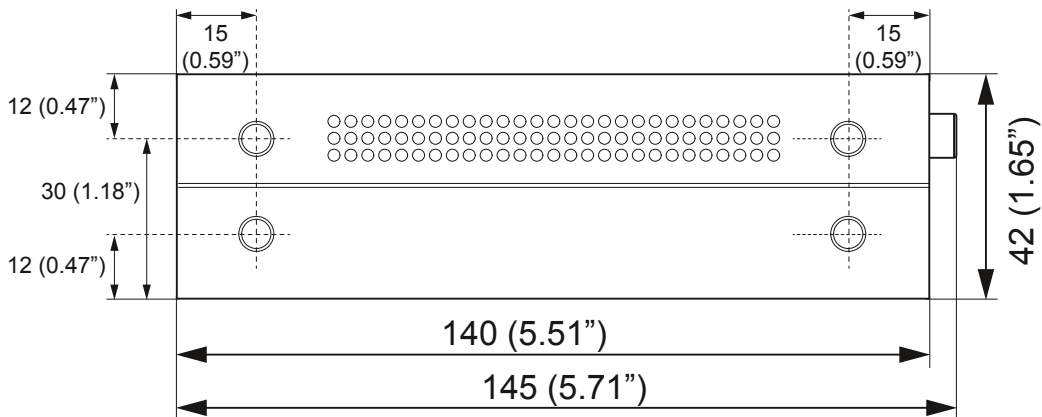

3 | Side views | dimensions in mm (inch)

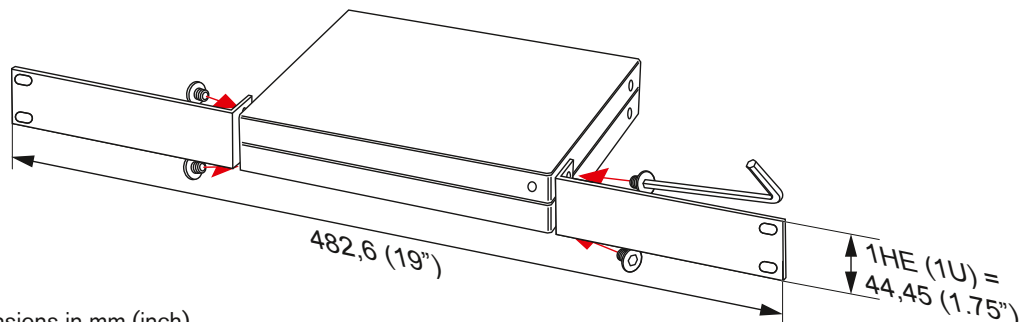

4 | Rack-mounting | dimensions in mm (inch)

# Connections

## Connectors

**⚠ ATTENTION!** - The power supply for the TMxCore is provided for ALL models via the 4-pin low-voltage socket (12 - 24 V DC) and the supplied 1178-R wide-range power supply unit (100 - 240 V AC/24 V DC, 2,7 A) **3**, which is approved for use with the TMxCore. Power supply for models 230017NR (Dante®) and 230018NR (RAVENNA®) via the AoIP network (PoE) is not possible!

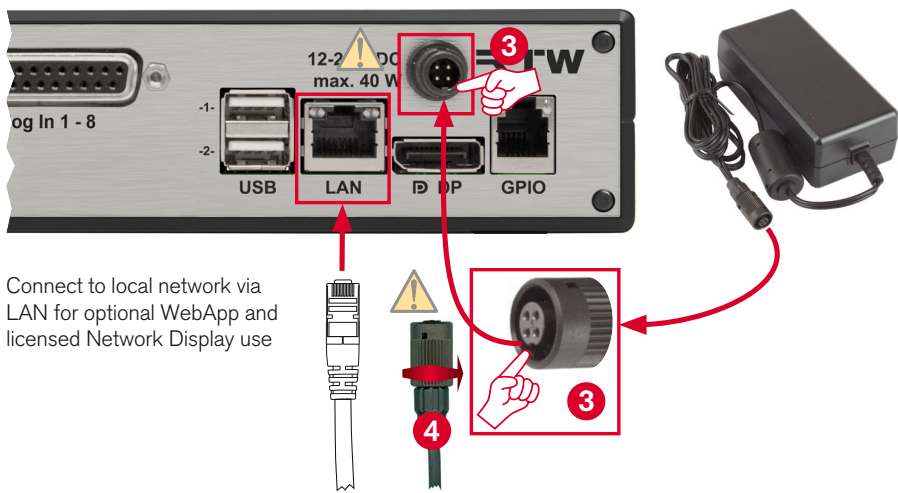
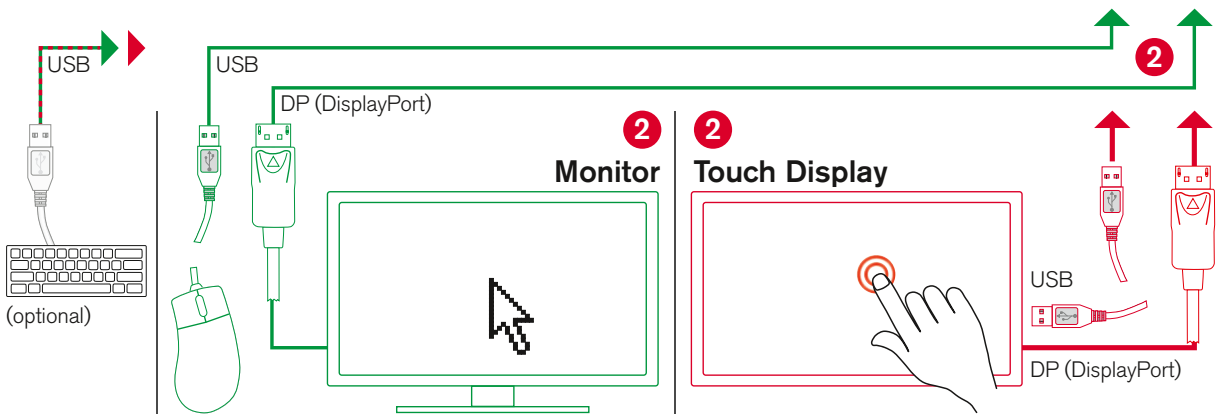
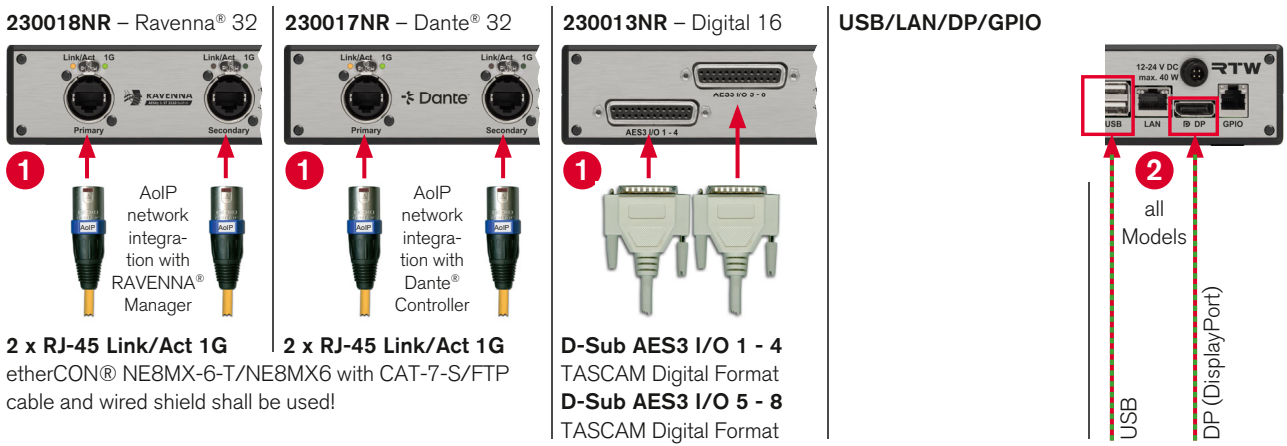

The use of the supplied power supply unit is mandatory  
100 - 240 V AC/24 V DC 2.7 A  
RTW 1178-R

# Specifications

## System

### General

Power requirements:	12 to 24 V DC
Power consumption:	max. 40 W
Connectors:	
all models:	1 x DisplayPort for the connection of any monitor or touch display 1 x 4-pin locking low voltage connector type Binder 710 (DC) for power supply 2 x USB A; USB 2.0 Full Speed connectors for: <ul style="list-style-type: none"><li>external computer mouse for control</li><li>external touch control</li></ul> 1 x GPIO (RJ-12-6P6C) for defined functions or preset recall 1 x LAN (RJ-45) for the connection to a local network for configuration via WebApp or use of the Network Display functionality
Model 230017NR, Model 230018NR:	2 x RJ-45: LAN/Ethernet built-in socket type NE8FD for Dante® resp. RAVENNA® Audio over IP (Primary, Secondary)
Model 230011NR:	2 x 25-pin D-Sub-F (1 x analog, 1 x digital)
Model 230013NR:	2 x 25-pin D-Sub-F (2 x digital)
Dimensions (W x H x D):	195 x 42 x 140 mm
Weight:	approx. 1.3 kg
Operating temperature:	+5° to +40° C

### Digital Inputs

230013NR:	8 AES3 inputs (transformer balanced, 110 Ω), 2 D-Sub-F built-in sockets, 25-pin, 4 inputs and 4 outputs on each socket Sampling rates: 44.1, 48, 96 kHz, synchronisation to digital input signal
-----------	--------------------------------------------------------------------------------------------------------------------------------------------------------------------------------------------------------

### Digital Outputs

230013NR:	8 AES3 outputs, 2 D-Sub-F built-in sockets, 25-pin, 4 inputs and 4 outputs on each socket
-----------	-------------------------------------------------------------------------------------------

## AoIP

230017NR:	32 Dante® AoIP network channels, 2 x RJ-45-built-in sockets (Primary, Secondary)
Sampling rates:	<ul style="list-style-type: none"><li>Dante® interface: 44.1, 48, 88.2, 96 kHz for all 32 channels</li><li>AES67 implementation: 44.1, 48 kHz only</li></ul>
230018NR:	32 RAVENNA®/AES67/ST 2110 AoIP network channels, 2 x RJ-45-built-in sockets (Primary, Secondary)
Sampling rates:	44.1, 48, 88.2, 96 kHz for all 32 channels
<b>Latency</b>	
Internal device latency:	3 ms (independent from sample rate)
Minimum network latency:	<ul style="list-style-type: none"><li>Dante®: 1 ms (Dante Controller™)</li><li>RAVENNA®: 0.25ms</li></ul>

Be aware that latency also depends on other network devices, such as switches and other networked products.

## Application Metering

Provides the familiar and further RTW Premium metering functions and the functions for loudness calculation, loudness range display and the chart for loudness over time.

Up to 4 instances are possible.

## General

### Input sources:

230013NR:	16 digital channels (8 x AES3 I/O format)
230017NR:	32 Dante® AoIP network channels
230018NR:	32 RAVENNA®/AES67/ST 2110 AoIP network channels

### Formate:

- Mono:	Mono, Stereo, Surround, Immersive, Multichannel multiple single channel signals selectable
- Stereo:	several 2-channel Stereo pairs selectable
- Surround:	<b>5.1</b> ; LCR, LCM, 4.0, 5.0, 5.1, 6.0, 6.1, 7.0, 7.1 selectable
- Immersive:	<b>5.1.4</b> ; 5.1.2, 5.1.4, 5.1.6, 7.1.2, 7.1.4, 7.1.6, 9.1.2, 9.1.4, 9.1.6, 22.2 (230017NR, 230018NR only), selectable
- Multichannel:	<b>8</b> ; 1 to 32 single channels in one instrument selectable



## Specifications (continued)

### Instruments

#### PPM

Analog or digital peakmeter/TP meter for peak level measurements

- Features:
- Bargraph display of the peak level with adjustable color, can be combined with Loudness display
  - Numerical value of the display
  - Wide selection of common and specific scales
  - Several adjustable parameters
  - Switchable Peakhold indicator
  - Peak Memory
  - Over indicator
  - Integrated phase correlation spot in Stereo mode

#### Moving Coil

Emulation of classical needle instruments

(The Moving Coil instrument is only available in 2-channel Stereos mode.)

- Features:
- PPM, Loudness, PPM + Loudness or VUdisplay
  - Channel can be displayed on single instruments or combined in one
  - Different British and VU scales selectable
  - Loudness scale acc. to selected Loudness standard

#### Loudness Sum

Loudness sum display of loudness measurements according to all relevant loudness standards and guidelines like ITU-R BS.1770-4/1771-1, EBU R128, ATSC A/85, ARIB, OP-59, AGCOM, CALM Act, LEQ(M), TASA, SAWA

- Features:
- Bargraph display of the summed Loudness values Momentary, Shortterm and Integrated of all channels of a format
  - Alternative display of the corresponding values for dialog-based measurements
  - Marker for the Target Level
  - Depending on the standard, selectable scales and adjustable tolerance ranges, among other things
  - Color scheme and orientation selectable
  - Test time control
  - Various control functions

#### Numeric

Comprehensive display of selected loudness and dialog-based measurement parameters

- Eigenschaften:
- Selectable parameters depending on the selected loudness standard
  - Color coding of ongoing or paused measurements and when target values are exceeded
  - Various control functions

#### Loudness Range (LRA)

Graphical representation of the loudness variance of the I measurement in short time intervals

- Features:
- Determination of fluctuations between loud and quiet or consistent loudness
  - Assessment of dynamics for the intended distribution channel
  - Multi-color bar graph display
  - Selectable scale range with adjustable areas (low range, comfort, high range)
  - Various display modes selectable
  - Alternative display for dialog-based measurements

#### Dialog Gated Loudness

Dialog-based Loudness measurements for ensuring dialog-based specifications like Netflix delivery standards

- Features:
- Supplement to the numeric instrument and measurement of dialog-related values, e. g. ID (Dialog-Based Integrated), SD (Dialog-Based Short-Time), D (Dialog Content Percentage)
  - Display of dialog-dependent summed values Momentary, Shortterm and Integrated
  - Display of the dialog-dependent volume range in the LRA instrument
  - Detector with definable channel assignment for detecting the presence of dialogue

#### Delay Compensation

Function for the compensation of system-related delays in dialog-based loudness measurements

- Features:
- All meters are aligned visually
  - Activation of audio outputs on all measuring instruments
  - All audio outputs remain time-aligned
  - Ensuring that playback corresponds precisely with the display

#### Chart

Instrument for graphically displaying and evaluating the progression over time of a loudness measurement or speech intelligibility.

- Features:
- Monitoring of the dynamics and consistency in broadcast, streaming, among others
  - Horizontal bargraphs with individually definable colors for evaluating the overall quality of the selected loudness values
  - Color change indicates the range in which the value moves
  - Continuously drawn graph of the progression over time of a selected value in a coordinate system
  - Additional vertical bargraph for the selected value
  - Adjustable time range



## Specifications (continued)

---

### Ratio

Display of the difference or ratio between two loudness measurements.

- Features:
- Monitoring of the ratios within one audio source:
    - Loudness to Dialog ratio (LDR)
    - Background to Dialog ratio (BDR)
  - Monitoring of the ratios between two different sources:
    - Comparison of the loudness before and after processing
    - Comparison of the loudness of different rendered layouts (immersive vs stereo, mono downmix etc.)

### LFE Bleed

Instrument for detecting unwanted high-frequency content entering the LFE channel

- Features:
- Display of the amount of unwanted high-frequency audio signals in the LFE channel above a user-definable frequency
  - LFE bargraph with TP60 scale
  - Color scheme and orientation selectable

### Stereo Correlator

Visualization of the phase relationship between the two channels of a stereo signal

- Features:
- Bargraph display of the phase relationship, Color and direction of deflection provide information about the ratio.
  - Used, for example, to assess the mono compatibility of the stereo signal.
  - Additional spot correlator between the PPM bargraphs of the Stereo signal

### Audio-Vektorskop

2-channel display of the phase interaction of any two channels on a rotated coordinate system (Lissajous figure)

- Features:
- Real-time display of the phase relationship between two channels
  - Channel pair for display freely selectable
  - Enables assessment of proper stereo imaging, phase alignment, and mono compatibility

### Realtime Analyzer (RTA)

Spectral distribution display of the frequency range of single channels, channel pairs or groups.

- Features:
- Input selection
  - Adaptable layouts and color visualisation
  - Scaling of the display area in several stages
  - Standard (Norm) frequency range with switchable high band
  - Low frequency range selectable
  - Resolution/amount of bands selectable in three steps

## Applikation Tools

Contains supplementary instruments and is available from scratch

### Action & OSC

Expansion of the measurement environment with powerful control functions

- Features:
- Creation of fully customizable buttons
  - Assignment of specific actions
  - Full Open Sound Control (OSC) support
  - Triggering/Sending of commands via OSC or TCP/UDP
  - Sending of HTTP requests
  - Control of key functions via incoming OSC commands (e. g. recall of presets or reference levels, Loudness control, adjustment of microphone gain)
  - Directly to mixers, automation systems, and external devices
  - Connection with all current buttons

### Label

Positionable text field

- Features:
- Naming screen views or labeling areas in the screen view
  - Freely selectable colors for text and background
  - Font type and size selectable
  - Horizontal or vertical orientation

### Clock

Integration of reliable timekeeping into the metering setup with a broadcaster-friendly design

- Features:
- Support of multiple time zones
  - Four distinct styles:
    - Digital Display with precise, high-contrast readout for hours, minutes and seconds
    - Analog Modern with minimalist face without numbers
    - Analog Classic with traditional face and numbers
    - Broadcast Style for studio use with a bold red ring indicating seconds



## Specifications (continued)

---

### Optional Software Licenses

For special applications where the extensive range of features is still not sufficient, additional tools and functions can be unlocked by purchasing and activating software licenses.

#### SW23010: Surround & Immersive Instruments

Expansion with instruments for immersive measurements that reflect what we hear: Immersive Sound Analyzer, Matrix Correlator, Multi Correlator and Polarscope

##### Immersive Sound Analyzer

- Features:
- Visualization of relationships between channels within up to two layers
  - Dynamic behavior of all elements represents the subjective listening impression
  - Monitoring of the balance at a glance
  - Display of the layer-related total loudness, extension shows loudness and phase relationships
  - Switchable Dominance indicator (DMI) for the display of the subjective perceived acoustic focal point
  - Switchable displays (PSI) for position and extension of phantom sound sources (Stereo width)
  - Color representation of the phase relationship on the PSI displays

##### Matrix Correlator

- Features:
- Compact matrix display of the phase relationship between all channels of the selected format
  - Color representation of the respective status
  - Complete overview makes it easy to detect potential phase issues

##### Multi Correlator

- Features:
- Display of the phase relationships between all channels of the selected surround or immersive format
  - Display of correlators between the speaker symbols of the format
  - Color representation and extent of the respective condition
  - LFE mode for displaying the relationships between each channel and the LFE channel

##### Polarscope

- Features:
- Extension of the stereo audio vectorscope principle to surround and immersive formats with a new algorithm
  - Display of correlations between channels in a spatially aware coordinate system
  - Recording the dynamic development of spatiality
  - Recording the energy balance between front and rear
  - Detection of phase issues or mirror symmetry

#### SW23020: Speech Intelligibility Instruments

Speech Intelligibility (SI) meter for AI-assisted, objective measurement of speech intelligibility

- Features:
- AI-assisted, objective measurement of speech intelligibility
  - Clear visual feedback to guide in balancing dialogue, effects, music, and background sounds
  - Display as Chart or bargraph meter

#### SW23030: Network Display: Add. Screen 1

Additional virtual screen for real-time audio measurements in the local network without additional hardware

- Features:
- Real-time audio measurements in the local network with a standard web browser
  - Other screen view of the preset can be selected for display
  - Remote monitoring of ongoing measurements far away from the device

#### SW23031: Network Display: Add. Screen 2

Second additional virtual screen for real-time audio measurements in the local network without additional hardware

--- Precondition: SW23030 ---

- Features:
- same as SW23030

#### SW23032: Network Display: Add. Screen 3

Third additional virtual screen for real-time audio measurements in the local network without additional hardware

--- Precondition: SW23030 and SW23031 ---

- Features:
- same as SW23030



## Specifications (continued)

---

### Items of Delivery

#### TMxCore - Digital 16

- TMxCore with Digital D-Sub
- Compact table-top device with connectors for
    - 16 digital inputs (8 x AES3 In, D-Sub),
    - 16 digital outputs (8 x AES3 Out, D-Sub),
    - local network (LAN),
    - any monitor (DisplayPort),
    - computer mouse/keyboard (USB),
    - GPIO (RJ-12),
    - power supply (4-pin locking low voltage connector)
  - Comprehensive set of measuring instruments
  - Mountable brackets for installation in 19" racks
  - Wide voltage power supply 1178-R (100 - 240 V AC/24 V DC 2.71 A, table-top unit with matching power cord for different power grids)
  - Quick start guide

**Order no.: 230013NR**

#### TMxCore - Dante® 32

- TMxCore with AoIP Dante® RJ-45
- Compact table-top device with connectors for
    - 32 channels Audio over IP Dante® (RJ-45),
    - local network (LAN),
    - any monitor (DisplayPort),
    - computer mouse/keyboard (USB),
    - GPIO (RJ-12),
    - power supply (4-pin locking low voltage connector)
  - Comprehensive set of measuring instruments
  - Mountable brackets for installation in 19" racks
  - Wide voltage power supply 1178-R (100 - 240 V AC/24 V DC 2.71 A, table-top unit with matching power cord for different power grids)
  - Quick start guide

**Order no.: 230017NR**

#### TMxCore - Ravenna® 32

- TMxCore with AoIP RAVENNA® RJ-45
- Compact table-top device with connectors for
    - 32 channels Audio over IP RAVENNA®/AES67/ST 2110 (RJ-45),
    - local network (LAN),
    - any monitor (DisplayPort),
    - computer mouse/keyboard (USB),
    - GPIO (RJ-12),
    - power supply (4-pin locking low voltage connector)
  - Comprehensive set of measuring instruments
  - Mountable brackets for installation in 19" racks
  - Wide voltage power supply 1178-R (100 - 240 V AC/24 V DC 2.71 A, table-top unit with matching power cord for different power grids)
  - Quick start guide

**Order no.: 230018NR**

# Example

Network Display: Virtual screen in the local network with web browser



© 11/2025 | Technical changes without notice.

RTW GmbH & Co. KG  
Am Wassermann 25 | 50829 Koeln (Cologne) | Germany  
Phone: +49 221 70 913-0  
Internet: [www.rtw.com](http://www.rtw.com) | E-Mail: [sales@rtw.com](mailto:sales@rtw.com)

**RTW**  
EYES ON YOUR AUDIO