

Data Sheet

SurroundControl 31960 Series

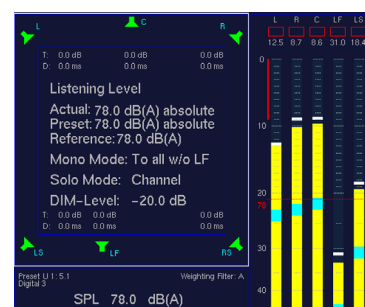

1 | Overview

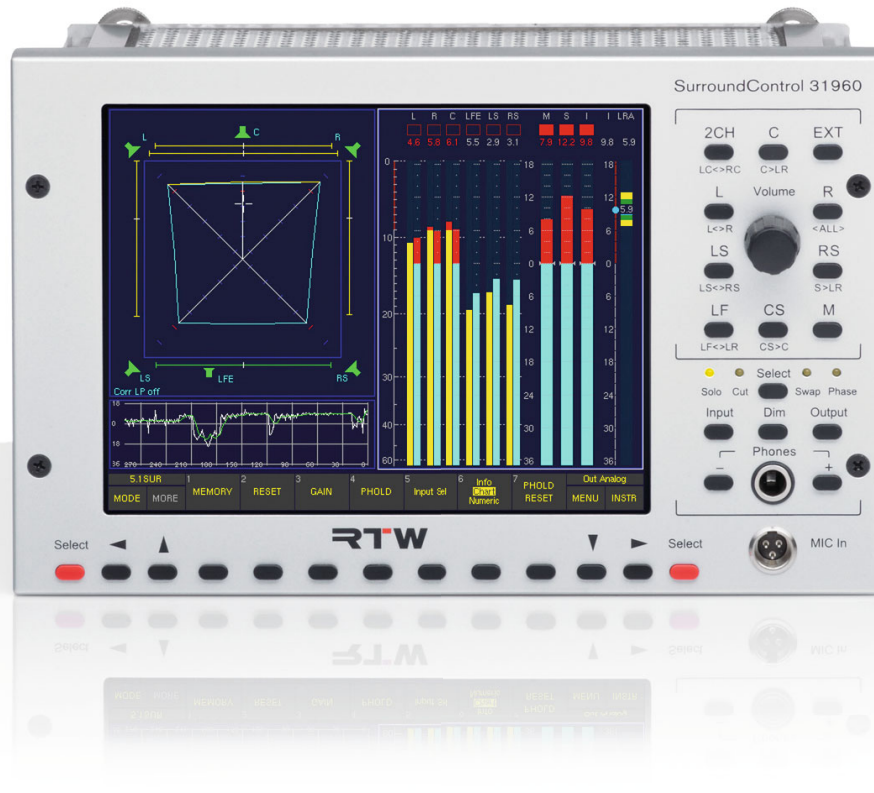

8-ch. Monitoring Controller ▪ **Surround Sound Analyzer** ▪ **Loudness** ▪ **Loudness Leq** ▪ **LRA** ▪ **PPM** ▪ **Dialnorm** ▪ **Vectorscope** ▪ **Correlator** ▪ **RTA** ▪ **Downmix** ▪ **AES3 Status** ▪ **SPL Meter** ▪ **BLITS** ▪ **3G-SDI** ▪ **Dolby® Decoder**



The unique combination of the powerful measuring functions of the RTW surround display devices with the control functions of an 8-channel monitoring controller and router offers in a half-19"/3U plug-in module for standard 19" rack-mount cabinets for wave form monitors a

universal system for comprehensive metering and acoustical controlling, analyzing and monitoring of surround sound. All functions can be controlled using the control panels on the front side. For display, a 6.5" VGA TFT display is integrated.

Monitoring Controller:

8-ch. volume control with preset, solo, cut, phase, channel swap, mono, trim, delay, dim, downmix matrix, signal routing, test signal and BLITS/EBU generator

Metering:

Multistandard PPM/True Peak up to 7.1, volume display, Loudness meter acc. to current standards (single channels, Momentary, Shortterm, Integrated), LRA instrument, chart recorder, Surround Sound Analyzer, 10-fold correlator with LFE mode, 1/3- and 1/6-octave RTA, downmix meter, 2- and 4-ch. audio vectorscope, SPL meter, Dialnorm meter, AES3 status monitor, BLITS analyzer

2 | Accessories



8-pair snake cable, 4 m

1186

- distributes 25-pin Sub-D connector to 8 XLR-F cable connectors
- "Meter In analog" and "Analog In" fan-out cable

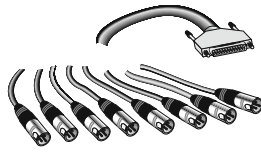

8-pair snake cable, 4 m

1163

- distributes 25-pin Sub-D connector to 8 XLR-M cable connectors
- "Analog Out" fan-out

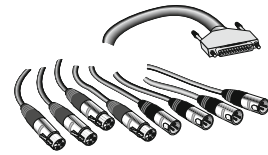

8-pair snake cable, 4 m

1167

- distributes 25-pin Sub-D connector to 4 XLR-F and 4 XLR-M cable connectors
- "Digital In/Out" fan-out



SurroundControl 31960 Series
Half-19" plug-in module with 6,5" VGA TFT display and control panels



Measuring microphone MM1

13720

- 3-pin XLR-M connector
- for SPL measurement via MIC In connector on the front side



Remote Display

30010

- 8.4" VGA color TFT monitor (640 x 480 pixel)
- function keys on the front side
- mains adapter and 5 m VGA connecting cable (all pins wired) included



Remote Control

30050

- 9-pin Sub-D-M connector
- attached 5 m cable
- internal addressable

© 05/2013 | Technical changes without prior notice.

3 | Dimensions

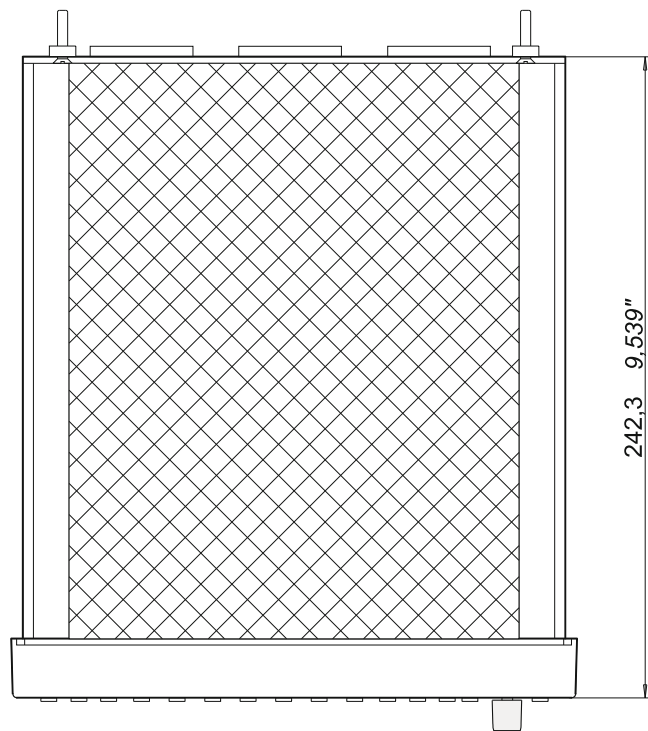
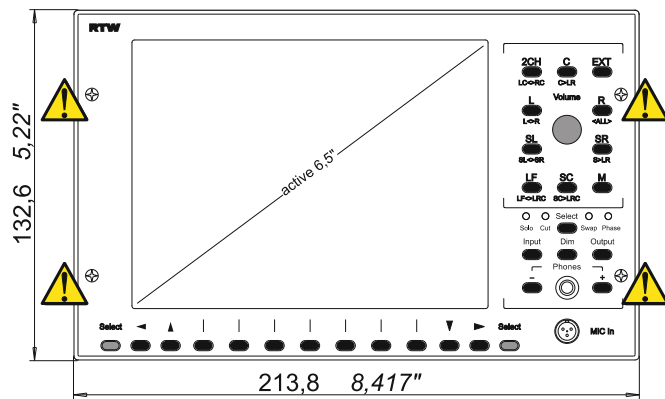
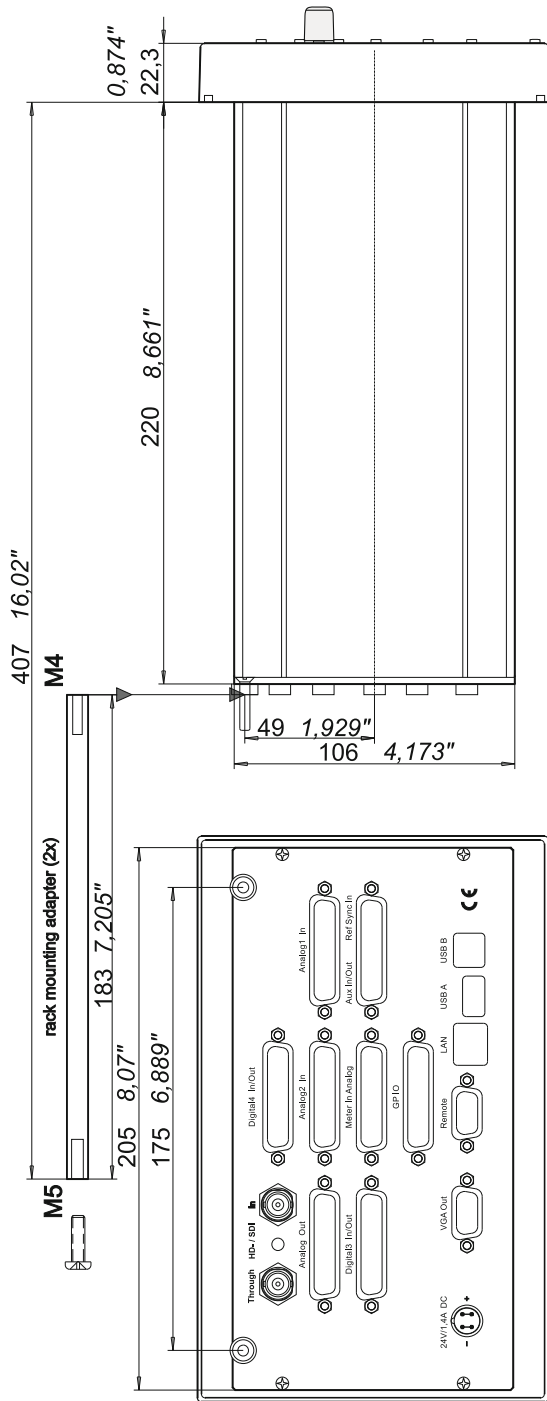

4 | Connection

4.1 | Connectors



ATTENTION!

Please use only suitable power supplies specified for this product and certified for your country. The RTW's wide voltage power supply 1178-R included should be used. An external overcurrent protective device (2 A max.) shall be installed when using an external 24 V DC power supply!

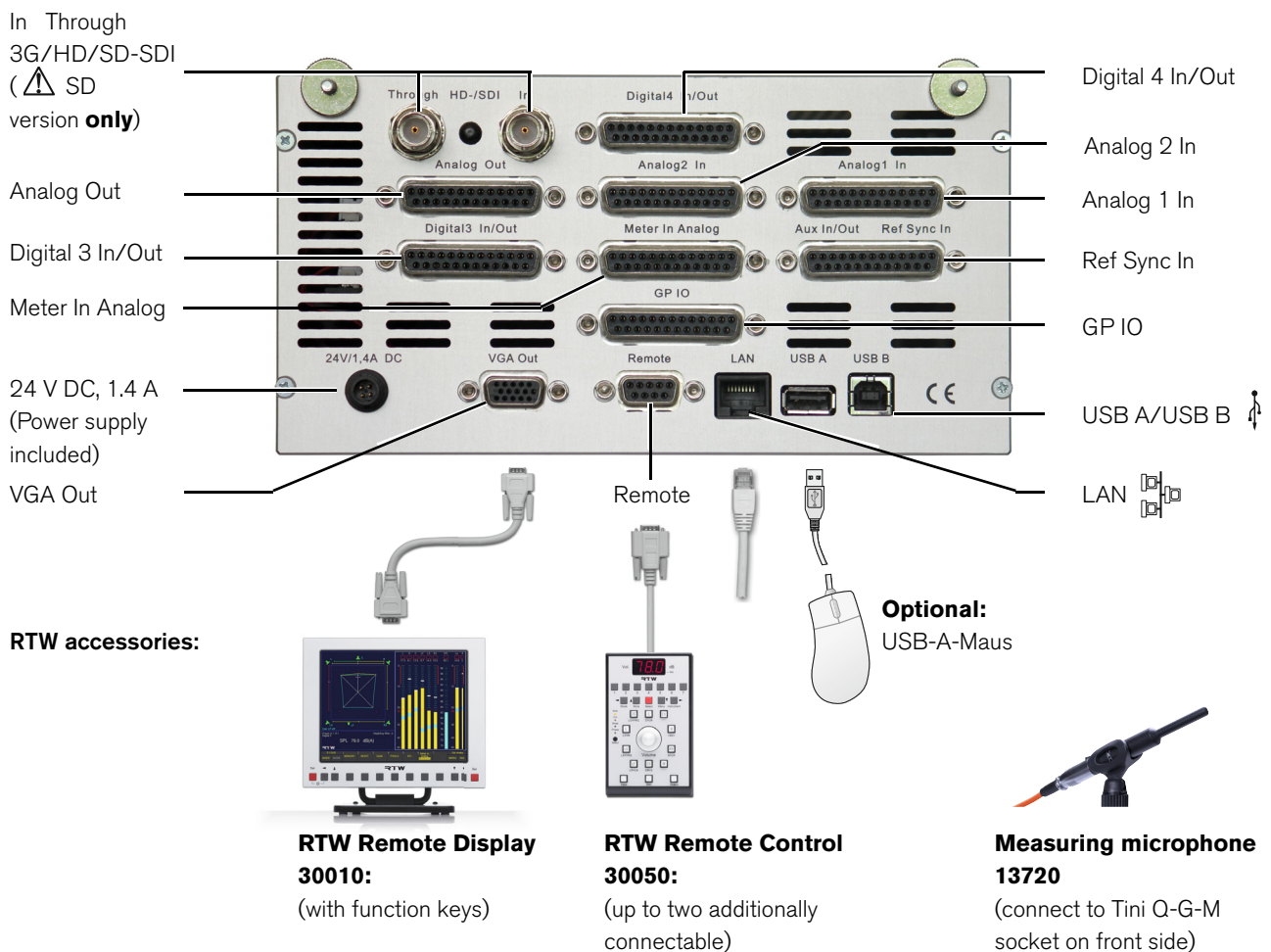

© 09/2011 | Technical changes without prior notice.

4.2 | Pin-Assignment

24 V - 1 A (4-pin locking low voltage, type Binder 710)

Pin: Function:

1	+24 V DC
2	+24 V DC
3	0 V
4	0 V



NOTE - An external overcurrent protective device (2 A max.) shall be installed when using an external 24 V DC power supply!

Remote (9-pin Sub-D-F, for Remote Control 30050 only)

Pin: Function:

1	Vcc +24 V DC
2	don't wire, for future use
3	Tx +
4	Rx -
5	GND
6	GND
7	Tx -
8	Rx +
9	don't wire, for future use

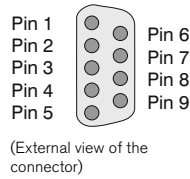

NOTE - The maximum total cable length to be used for Remote Control 30050 units is 25 meters!

USB-A

Standard USB 1.1 interface for connecting a computer mouse

LAN

RJ-45-Standard-Netzwerkanschluss

VGA Out (15-pin Sub-D-F)

Pin: Function:

1	R Video-Signal
2	G
3	B
4	don't wire, for future use
5	GND
6	GND
7	GND
8	GND
9	don't wire, for future use
10	GND
11	Tx - Remote Display 30010
12	Rx - Remote Display 30010
13	H-sync
14	V-sync
15	don't wire, for future use

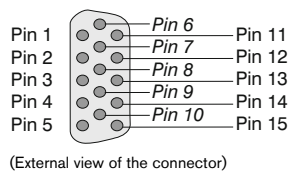

NOTE - The VGA cable shall be 10 to 15 m maximum length! When connecting an RTW Remote Display 30010 all pins of the VGA connecting cable must be wired!

MIC In (3-pin Tini O-G-M)

Pin: Function:

1	Shield/case
2	+, hot
3	-, cold

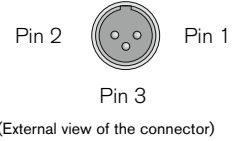

Meter In analog, Analog 1 In, Analog 2 In (25-pin Sub-D-F)

Pin: Function:

1	Input Analog 8 (+, hot)
14	Input Analog 8 (-, cold)
2	Shield/case
15	Input Analog 7 (+, hot)
3	Input Analog 7 (-, cold)
16	Shield/case
4	Input Analog 6 (+, hot)
17	Input Analog 6 (-, cold)
5	Shield/case
18	Input Analog 5 (+, hot)
6	Input Analog 5 (-, cold)
19	Shield/case
7	Input Analog 4 (+, hot)
20	Input Analog 4 (-, cold)
8	Shield/case
21	Input Analog 3 (+, hot)
9	Input Analog 3 (-, cold)
22	Shield/case
10	Input Analog 2 (+, hot)
23	Input Analog 2 (-, cold)
11	Shield/case
24	Input Analog 1 (+, hot)
12	Input Analog 1 (-, cold)
25	Shield/case

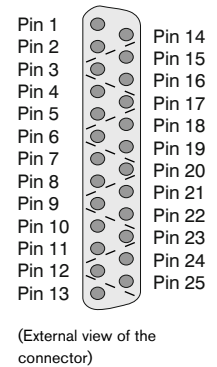

Analog Out (25-pin Sub-D-F)

Pin: Function:

1	Output Analog 8 (+, hot)
14	Output Analog 8 (-, cold)
2	Shield/case
15	Output Analog 7 (+, hot)
3	Output Analog 7 (-, cold)
16	Shield/case
4	Output Analog 6 (+, hot)
17	Output Analog 6 (-, cold)
5	Shield/case
18	Output Analog 5 (+, hot)
6	Output Analog 5 (-, cold)
19	Shield/case
7	Output Analog 4 (+, hot)
20	Output Analog 4 (-, cold)
8	Shield/case
21	Output Analog 3 (+, hot)
9	Output Analog 3 (-, cold)
22	Shield/case
10	Output Analog 2 (+, hot)
23	Output Analog 2 (-, cold)
11	Shield/case
24	Output Analog 1 (+, hot)
12	Output Analog 1 (-, cold)
25	Shield/case

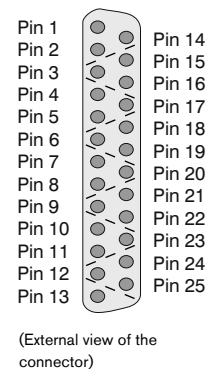

Pin-Assignment (continued)

Digital 3 In/Out, Digital 4 In/Out (25-pin Sub-D-F)

Pin: Function:

1	Audio-Output digital 4 (+, hot)	Pin 1		Pin 14
14	Audio-Output digital 4 (-, cold)	Pin 2		Pin 15
2	Shield/case	Pin 3		Pin 16
15	Audio-Output digital 3 (+, hot)	Pin 4		Pin 17
3	Audio-Output digital 3 (-, cold)	Pin 5		Pin 18
16	Shield/case	Pin 6		Pin 19
4	Audio-Output digital 2 (+, hot)	Pin 7		Pin 20
17	Audio-Output digital 2 (-, cold)	Pin 8		Pin 21
5	Shield/case	Pin 9		Pin 22
18	Audio-Output digital 1 (+, hot)	Pin 10		Pin 23
6	Audio-Output digital 1 (-, cold)	Pin 11		Pin 24
19	Shield/case	Pin 12		Pin 25
7	Audio-Input digital 4 (+, hot)			
20	Audio-Input digital 4 (-, cold)			
8	Shield/case			
21	Audio-Input digital 3 (+, hot)			
9	Audio-Input digital 3 (-, cold)			
22	Shield/case			
10	Audio-Input digital 2 (+, hot)			
23	Audio-Input digital 2 (-, cold)			
11	Shield/case			
24	Audio-Input digital 1 (+, hot)			
12	Audio-Input digital 1 (-, cold)			
25	Shield/case			

(External view of the connector)



NOTE - The AES3 inputs are permanently terminated with 110 Ω.

GP IO (General-purpose Input/Output) (25-pin Sub-D-F)

Pin: Function:

1	IN	Function key 1	Pin 1		Pin 14
2	IN	Function key 2	Pin 2		Pin 15
3	IN	Function key 3	Pin 3		Pin 16
4	IN	Function key 4	Pin 4		Pin 17
5	IN	Function key 5	Pin 5		Pin 18
6	IN	Function key 6	Pin 6		Pin 19
7	IN	Function key 7	Pin 7		Pin 20
8	IN	Control key MODE	Pin 8		Pin 21
9	IN	Control key MENU	Pin 9		Pin 22
10	IN	Control key MORE	Pin 10		Pin 23
11	IN	Control key INSTR(UMENT)	Pin 11		Pin 24
12	IN	Key SEL(ECT)	Pin 12		Pin 25
13	IN	Control key Input			
14	IN	Control key DIM			
15	IN	Control key Output			
16	IN	Control key Mute			
17	OUT	Output 1			
18	OUT	Output 2			
19	OUT	Output 3			
20	OUT	Output 4			
21	OUT	Output 5			
22	OUT	Output 6			
23	OUT	Output 7			
24	OUT	Output 8			
25		Common potential and Shield/case			

(External view of the connector)



NOTE - The pins each have to be switched to pin 25 for activating the corresponding function. All GP IO inputs are active low. All GP IO are set to active low by factory, but logic state and switching function can be changed. Refer to paragraph **External control via GP IO connector** included in the PDF version of the operating manual for more detailed information.

Ref Sync In (25-pin Sub-D-F)

Pin: Function:

1	Ref Sync In (AES3), (+, hot)	Pin 1		Pin 14
14	Ref Sync In (AES3), (-, cold)	Pin 2		Pin 15
2	Shield/case	Pin 3		Pin 16
15	don't wire, for future use	Pin 4		Pin 17
3	don't wire, for future use	Pin 5		Pin 18
16	Shield/case	Pin 6		Pin 19
4	don't wire, for future use	Pin 7		Pin 20
17	don't wire, for future use	Pin 8		Pin 21
5	Shield/case	Pin 9		Pin 22
18	don't wire, for future use	Pin 10		Pin 23
6	don't wire, for future use	Pin 11		Pin 24
19	Shield/case	Pin 12		Pin 25
7	don't wire, for future use			
20	don't wire, for future use			
8	Shield/case			
21	don't wire, for future use			
9	don't wire, for future use			
22	Shield/case			
10	don't wire, for future use			
23	don't wire, for future use			
11	Shield/case			
24	don't wire, for future use			
12	don't wire, for future use			
25	Shield/case			

(External view of the connector)



NOTE - The AES3 Sync Input is permanently terminated with 110 Ω.

3G/HD/SD-SDI In Through (BNC-F; SD version only)

Pin: Function:

Pin: Signal
Ring: Shield/case



(External view of the connector)



NOTE - Input signals are active looped through without processing.

Block diagram of the 3G/HD/SD-SDI interface

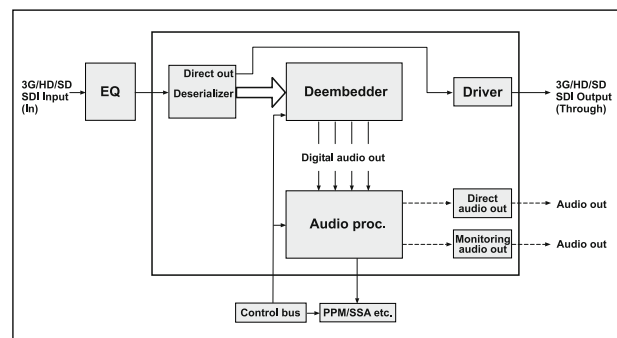

© 05/2013 | Technical changes without prior notice.

5 | Specifications

General

Power requirements:	+24 V DC (mains adapter included)
Current drain (nominal):	1.4 A (power-up current is much higher!)
Display:	6.5" VGA TFT (640 x 480 pixel, 256 colors, 60 Hz)
Connectors:	1 x 4-pin low voltage connector type 710 (DC) 1 x 9-pin Sub-D-F (Remote) 1 x 15-pin Sub-D-F (VGA out) 1 x LAN, 1 x USB A, 1 x USB B 8 x 25-pin Sub-D-F 1 x Tini Q-G-M (measuring microphone) 1 x 6,35 mm jack plug (phones) 2 x BNC (SDI: with SD version)
Dimensions:	218.8 x 132.6 x 242.3 mm (W x H x D, half-19"/3U)
Weight:	2.5 kg
Operating temperature range:	0° to +45° C

Functions

- multi format surround peakmeter (5.1, 6.1, 7.1) with True Peak
- 2-channel peakmeter with True Peak
- Multi-channel peakmeter with True Peak
- Loudness meter acc. to current standards
- Selectable Loudness Range instrument (LRA)
- selectable SPL meter
- Surround Sound Analyzer
- 10-fold multi phase meter with LFE mode
- 1/3- and 1/6-octave spectrum analyzer
- 2- and 4-channel audio vectorscope
- Dialnorm meter
- Downmix meter
- AES3 status monitor
- 8-channel monitoring controller
- Audio test signal generator
- BLITS analyzer and generator
- EBU 3304 surround ident generator
- GLITS, EBU 3304, ARD-WDR Stereo test signal generator
- 3G/HD/SD-SDI deembedder (31900SD)
- Dolby® E/Dolby® AC-3/Dolby® DD+ decoder (31900SD)
- Alarm functions

Analog Inputs

Metering:	8 analog inputs, Sub-D-F connector, 25-pin
Monitoring/Metering:	2 x 8 analog inputs, Sub-D-F connector 25-pin
- Adjustment range:	Level Offset via software: ± 8 dB
- Maximum input level:	+24 dBu
- Impedance:	> 10 k Ω , electronically balanced
- Frequency response:	20 Hz to 22 kHz, ± 0.25 dB @ 48 kHz
- THD+N:	< 105 dB @ 48 kHz
- Crosstalk:	< 105 dB (Frequency range 22 Hz to fs/2)
Measuring microphone:	input balanced, phantom powered, Tini Q-G-M connector for measuring microphones with open circuit voltage of 15 mV/Pa @ 1 kHz

Digital Inputs

Monitoring/Metering:	2 x 4 AES3 inputs, Sub-D-F connector, 25-pin, each connector features 4 in- and 4 outputs
3G/HD/SD-SDI (option):	2 x BNC (In, Through; SD version only)
External clock signal:	AES3 signal, Sub-D-F connector, 25-pin
Sampling rates:	44.1, 48, 96 kHz, synchronisation via digital input signal or Ref Sync input

Analog Outputs

Monitoring:	8 analog outputs, electronically balanced, Sub-D-F connector, 25-pin
- Maximum nominal level:	for 0 dBFS selectable: <ul style="list-style-type: none">▪ EBU RP68 (+18 dBu),▪ ARD (+15 dBu);▪ SMPTE RP155 (+24 dBu)▪ User (+18 .. +24 dBu)
Frequency range:	20 Hz to 22 kHz, ± 0.25 dB @ 48 kHz
- THD+N:	< 100 dB

Digital Outputs

Monitoring:	2 x 4 AES3 outputs, Sub-D-F connector, 25-pin, each connector features 4 in- and 4 outputs referenced to digital inputs or internal clock, 44.1, 48, 96 kHz
Sampling rates:	

Monitoring Controller

Volume control:	control range > 85 dB, mute, calibration in dB(A) possible
Channel functions:	<ul style="list-style-type: none">▪ Solo,▪ Cut,▪ Phase,▪ Mono (Mono-to-Center or Mono-to-LR),▪ Side Swap,▪ Center-to-LR,▪ Rear-to-Front,▪ LF-to-Front,▪ DIM▪ Mute
Channel offset:	level: ± 10 dB, delay: 0 - 50 ms, respectively selectable for each channel, independent for both domains, can be stored in up to 5 Level/Delay Trim Sets
Downmix matrix:	2-Channel mix of the monitoring surround signal, 2-channel mix derived from one of the inputs or decoder outputs, mixing coefficients selectable for each channel (if internal downmix matrix is used)

Program Meter: Peak Program Meter (PPM)

General (PPM)

Input sources:	Metering input or selected monitoring input
Surround peakmeter:	for all formats up to 7.1
Track layout:	selectable for 5.1 surround: <ul style="list-style-type: none">▪ SMPTE-TV (ITU, SSF),▪ SMPTE-Film,▪ DTS,▪ Film (L, C, R, LF, LS, RS) selectable for 7.1 DD+: <ul style="list-style-type: none">▪ L, C, R, LS, RS, LSR, RSR, LFE▪ L, R, C, LFE, LS, RS, LSR, RSR
Multi-channel peakmeter:	up to 8 single channels or up to 4 x 2-channel stereo pairs
2-Channel peakmeter:	for the defined stereo channel pair L and R
additional 2-Ch. PPM:	selectable, for external signals or internal generated Lo/Ro signals (2-Ch. Downmix), selectable, indication of the total sound pressure level calculated from the individual channels
SPL meter:	



Specifications (continued)

Indicators:	<ul style="list-style-type: none"> Peak level, RMS level (linear, A-, C-, M-, CCIR-, K-weighted), Peak hold, Numerical value of the peak hold level, Digital Over,
Functions:	<ul style="list-style-type: none"> Gain (+20 dB, +40 dB acc. to standard), Peak hold on/off, RMS on/off, Memory, Reset, Alarm (threshold over, silence)

Analog Peakmeters (PPM)

Analog scales:	<ul style="list-style-type: none"> DIN5dB, DIN10dB, Nordic (N9, IEC 268 Type I), British (Type IIa, IEC 268-10A), British (Type IIb, IEC 268-10A), VU, Zoom +/-10dB, Zoom +/-1dB, SMPTE 24 dB – abs, SMPTE 20 dB – rel, NHK
Integration time:	according to standard or 300 ms, 150 ms, 20 ms, 10 ms, 1 ms, 0.1 ms
Reference level (PML):	according to standard: +6 dBu (DIN, Nordic), +8 dBu (British) <ul style="list-style-type: none"> NHK: 0 dB @ system reference level SMPTE 24 dB – abs: 0 dB @ 0 dBu SMPTE 20 dB – rel: 0 dB @ +4 dBu selectable offset (± 8 dB)

Digital Peakmeters (PPM)

Word width:	24 bit
Digital scales:	<ul style="list-style-type: none"> TP60 (+3 to -60 dB) TP20 (+3 to -20 dB) Dig60dB (0 dBFS to -60 dBFS absolute), Dig20dB (0 dBFS to -20 dBFS absolute), Dig+18dB.0dB (18 dB to 0 dB relative, 0 dB @ -18 dBFS), Dig+18dB.0.-18dB (18 dB to -18 dB rel., 0 dB @ -18 dBFS), Dig+20.0.-40dB (20 dB to -40 dB rel., 0 dB @ -20 dBFS), ARD +9 dB to -60 dB (0 dB @ -9 dBFS) <q>DIN5dB, <q>DIN10dB, <q>Zoom +/-10dB, <q>Zoom +/-1dB (0 dB @ headroom), <q>Nordic (+6 dB @ headroom setting), <q>British IIa (*6" @ headroom setting), <q>British IIb (+8 dB @ headroom setting),
Headroom:	selectable in 1 dB steps from 0 dBFS to -20 dBFS
Integration time (Attack):	acc. to corresponding standard or selectable: sample or 150 ms, 20 ms, 10 ms, 1 ms, 0.1 ms 40 dB
Additional Gain:	
High-pass filter:	Off, 5 Hz, 10 Hz, 20 Hz
Peak Hold indicator:	integration time sample or same as level indication
Over indicator (Clip):	
- Operating threshold:	FS, FS-1LSB, FS-2LSB, -0.1 dBFS, -0.5 dBFS, -1 dBFS, -2 dBFS, -3 dBFS
- Attack time:	1 to 15 samples
- Word width:	16 to 24 bit selectable

Program Meter: Loudness Meter

General (Loudness)

Standards:	EBU R128, ITU-R BS.1770-2/1771, ATSC A/85, ARIB, Custom mode (parameter adjustable)
Display:	<ul style="list-style-type: none"> Bargraphs vertical for each single channel M bargraph (Momentary - summation of momentary loudness values of all channels for a short span of time) S bargraph (Shortterm - loudness value of an adjustable danymic time frame, summation of Momentary values) I bargraph (Integrated - integrated loudness value), infinite or manual control
Bargraph display:	<ul style="list-style-type: none"> Loudness only Loudness + PPM
Numerich display:	for shortterm (S) and integrated (I) values für momentary (M) and shortterm (S) values
Chart display:	K filter acc. to ITU BS.1770
Weighting filter:	
Alarm threshold:	adjustable, from 0 to 9 in steps of 0.5
Alarm hold:	1 s, 5 s (default), or manual reset

EBU R128

Scales:	EBU+9, EBU+18, EBU+9a, EBU +18a
---------	---------------------------------

ITU-R BS.1770-2/1771

Scales:	ITU+9, ITU0
---------	-------------

ATSC A/85

Scales:	ITU+9, ATSCO, ATSCOa
---------	----------------------

ARIB

Scales:	ATSCO
---------	-------

Custom-Modus (parameter adjustable)

Scales (Range/Target Level):	<ul style="list-style-type: none"> EBU+9 (-18 to +9 LU/-23 LUFS) EBU+18 (-36 to +18 LU/-23 LUFS) EBU+9a (-41 to -14 LUFS/-23 LUFS) EBU+18a (-59 to -5 LUFS/-23 LUFS) EBU0 (-60 to 0 LUFS/-23 LUFS) ITU+9 (-18 to +9 LU/-24 LKFS) ITU0 (-30 to 0 LKFS/-24 LKFS) ATSCO (-60 to 0 LKFS/-24 LKFS) ATSCOa (-30 to 0 LKFS/-24 LKFS)
Reference value for 0 display of LU/LUFS- scales:	adjustable, 1-dB-Schritte von -30 bis -10 LU/LUFS
LUFS/LKFS Headroom:	adjustable, 1-dB-Schritte von 0 bis -30 LUFS/LKFS
Window Time Momentary:	selectable: 200 ms, 300 ms, 400 ms, 500 ms, 600 ms, 700 ms, 800 ms, 900 ms, 1000 ms 3 s, time frame selectable from 1 to 20 s
Integration time Short:	
Integrated Silence Gate:	-70.0 LUFS; adjustable in ther range from -80.0 LUFS to -40.0 LUFS in steps of 0.5 LUFS, detachable
Integrated Relative Gate:	-10.0 LU; adjustable in the range from -40.0 LU to 0 LU in steps of 0.5 LU, detachable
Level adjustment for the summation:	<ul style="list-style-type: none"> 0.0 dB (L, R, C), adjustable between -3 and +3 dB in steps of 0.5 dB +1.5 dB (LS, RS), adjustable between -3 and +3 dB in steps of 0.5 dB Off (LFE), selectable: Off, 0 dB, 10 dB



Specifications (continued)

Loudness Range Instrument (LRA)

Display:	switchable
Mode:	selectable: LRA Bar, MagicLRA, MagicLRA + I, MagicLRA + I + Num
Scale range:	selectable: 6 LU, 10 LU, 20 LU, 30 LU
LRA low range:	2 LU; adjustable in the range from 1 to 20 LU in steps of 1 LU
Comfort zone:	4 LU; adjustable in the range from 1 to 20 LU in steps of 1 LU
LRA high range:	depends on the selected scale range and the spread of the comfort zone
Colors:	selectable for each range

SPL Meter

Measuring range:	Low: 50 – 78 dB(SPL) Mid: 70 – 98 dB(SPL) High: 90 – 118 dB(SPL)
Input sources:	internal (mix of the surround channels), external (MIC In measuring input, Tini Q-G-M connector)
Weighting:	linear, A, C, CCIR, K
Integration time:	F (125 ms), S (1 s)

Surround Sound Analyzer

(available in surround mode only)

Indicators:	<ul style="list-style-type: none"> graphics display indicating the single channel and total program loudness acc. to selected weighting filter (Total Volume Indicator) correlation of adjacent channels position and width of phantom sound sources (PSI) Dominance indicator (DMI)
-------------	--

Multi-fold Phase Meter

Surround mode	
- Display mode:	<ul style="list-style-type: none"> for each channel pair in 5.1/7.1 DD+ format LFE mode to display the correlation between each single channel and LFE channel
- Filter:	low pass filter switchable (300 Hz)
Multi-channel mode	
- Display mode:	for the defined stereo channel pair
2 Channel Stereo mode	
- Display mode:	for the defined stereo channel pair L and R and the external channels Lext and Rext

Audio Vectorscope

Surround mode	
- Modes:	<ul style="list-style-type: none"> 2-channel 4-channel (fixed: L-R upper part, LS[R]-RS[R] lower part)
- Input sources:	in 2-channel mode selectable (e. g. 5.1): L-R, LS-RS, L-LS, R-RS, L-C, C-R, Lext-Rext, Lo-Ro
- Auto Gain:	fast/slow
- Functions:	<ul style="list-style-type: none"> Indication: Fast - Slow Display: Normal - M/S
- Phase meter:	in 2- and 4-ch. mode for displayed channel pairs
Multi-Channel mode	
- Input sources:	defined and selected stereo channel pair
2 Channel Stereo mode	
- Input sources:	L-R
- Auto Gain:	fast/slow
- Functions:	<ul style="list-style-type: none"> indication: Fast - Slow display: Normal - M/S
- Phase meter:	for the defined stereo channel pair L and R and the external channels Lext and Rext

Spectrum Analyzer (RTA)

Input sources:	Selectable: all channels without LF, Rear, L/R, single channels, measuring input
----------------	--

Frequency range:	<ul style="list-style-type: none"> Norm: 20 Hz to 20 kHz, add-on band > 20 kHz to fs/2 LF: 5 Hz to 5 kHz
Number of bands:	<ul style="list-style-type: none"> 1/3-octave: 31 bands, Filter acc. to IEC 225 class 2 1/6-octave: 61 bands
Measuring range:	45 dB
Resolution:	1, 2, 3 dB
Functions:	<ul style="list-style-type: none"> Input select Peak hold on Display hold Cursor readout A-, C-weighting Integration time Set reference Scaling Frequency range
Integration time:	I (impulse), F, S, peak (10 ms)

Downmix Meter

(available in surround mode only)

Input sources:	internal generated downmix signals, external 2-channel signals or internal decoded downmix
Indicators:	<ul style="list-style-type: none"> Peak level Peak hold RMS Audio vector scope Phase meter for scales and standards see analog/digital peakmeter

Test Signal Generator (1)

Signals:	<ul style="list-style-type: none"> pink noise: 20 Hz to 20 kHz, 200 Hz to 20 kHz octave-band noise sine wave
Level:	<ul style="list-style-type: none"> 3 selectable levels: -9, -18, -20 dBFS RMS variable in 1 dB steps: from 0 to -99 dBFS
Outputs:	analog or digital

Test Signal Generator (2)

Signals:	noise/sine wave
Level:	0 dBFS to -60 dBFS
Frequency (Hz):	20, 25, 50, 100, 250, 500, 1k, 2k, 4k, 8k, 10k
Outputs:	direct out, analog or digital

Test Signal Generator (3)

Surround identification:	<ul style="list-style-type: none"> BLITS or EBU 3304 optional intro from stored wav-file digital or analog offset, selectable in steps of 1 dB in the range from -12 to +12 dB selectable 10 dB LF boost for EBU 3304
Stereo identification:	<ul style="list-style-type: none"> GLITS, EBU 3304 or ARD-WDR optional intro from stored wav-file digital or analog offset, selectable in steps of 1 dB in the range from -12 to +12 dB
Outputs:	direct out, analog or digital

BLITS Analyzer

Surround identification:	automatic detection and analysis of incoming BLITS test tones
Displays:	<ul style="list-style-type: none"> incoming channels channel allocation level with difference phase resp. delay polarity test duration number of runs Errors will be displayed in red
Alarm displays:	for channel allocation, level, phase/delay, polarity



Specifications (continued)

AES3 Status Monitor

Indicators:	<ul style="list-style-type: none"> channel data are displayed as plain text, hex or binary channel selectable audio bit activity hardware status
-------------	--

Dolby® option (31960SD)

Decoder modes:	<ul style="list-style-type: none"> Dolby® DD+ Dolby® E Dolby® AC-3 Dolby® Pro Logic I
Decoder inputs:	analog, digital, 3G/HD/SD-SDI
Decoder outputs:	to monitoring and metering and/or direct out
Downmix modes:	Lt/Rt, Lo/Ro, Mono, Mute

3G/HD/SD-SDI option (31960SD)

Inputs:	1 x BNC, display of any combination of max. 8 channels, no video signals
Outputs:	1 x BNC Through, selected input signals are active looped through without processing

System

Remote control:	RS-422, for connecting up to three units of Remote Control 30050. Sub-D-F connector, 9-pin
GP IO (parallel):	<ul style="list-style-type: none"> 16 inputs, functions selectable, 8 outputs for indication of alarm events (threshold over, silence, Digital Over), or as defined in Sub Presets.
- GP IO inputs:	Sub-D-F connector, 25-pin active low, pulse or momentary
- GP IO outputs:	active high or low, (0.1 s, 0.5 s, 1 s, 2 s, manual)
USB:	for connecting a computer mouse, USB 1.1, I _{max} 0.5 A
Network:	Software update, export and import of User Presets, wav file upload
Video:	VGA, 640 x 480, 256 colours, 60 Hz, for connecting the optional 8.4-inch Remote Display 30010 or a standard VGA monitor

Remote Control 30050 (optional accessory)

Dimensions:	106 x 55 x 176 mm (W x H x D)
Weight:	600 g with cable
Connection:	fixed cable, 5 m, with Sub-D-m connector, 9-pin
Max. cable length:	25 m
Control panel:	<ul style="list-style-type: none"> volume adjusting knob keys for controlling the monitoring keys for controlling the instrument functions and the menus

Remote Display 30010 (optional accessory)

Power requirements:	+24 V DC
Current drain (nominal):	630 mA (power-up current is much higher!)
Display:	8.4" VGA TFT (640 x 480 pixel, 256 colors, 60 Hz)
Connectors:	1 x 4-pin low voltage connector type 710 (DC) 1 x 15-pin Sub-D-F (VGA)
Control panel:	keys for controlling the instrument functions and the menus
Dimensions:	213.5 x 200 x 55 mm (W x H x D, with table stand)
Weight:	2.5 kg
Operating temperature range:	0° to +45° C

Items supplied:

SurroundControl 31960:	<ul style="list-style-type: none"> Half-19"/3U plug-in module with TFT display and control panels for standard 19" rack-mount cabinets for wave form monitors rack-mounting adapters (two pieces) for cases with 407 mm depth Wide voltage power supply 1178-R (100 - 240 V AC/24 V DC 2.71 A with corresponding power cable) operating manual <p>Order number: 31960</p>
SSurroundControl 31960SD:	<ul style="list-style-type: none"> Half-19"/3U plug-in module with TFT display and control panels for standard 19" rack-mount cabinets for wave form monitors 3G/HD/SD-SDI deembedder interface Dolby® E/Dolby® AC-3/Dolby® DD+ decoder rack-mounting adapters (two pieces) for cases with 407 mm depth Wide voltage power supply 1178-R (100 - 240 V AC/24 V DC 2.71 A with corresponding power cable) operating manual <p>Order number: 31960SD</p>

Optional accessories

- Remote Display **30010** (VGA monitor with function keys)
- additional Remote Control **30050** (up to two connectable)
- snake cable **1186** (8 x XLR-f connector to Sub-D-m connector, 25-pin, length 4 m)
- snake cable **1163** (8 x XLR-m connector to Sub-D-m connector, 25-pin, length 4 m)
- snake cable **1167** (4 x XLR-m and 4 x XLR-f connector to Sub-D-m connector, 25-pin, length 4 m)

© 05/2013 | Technical changes without prior notice.

Block diagram

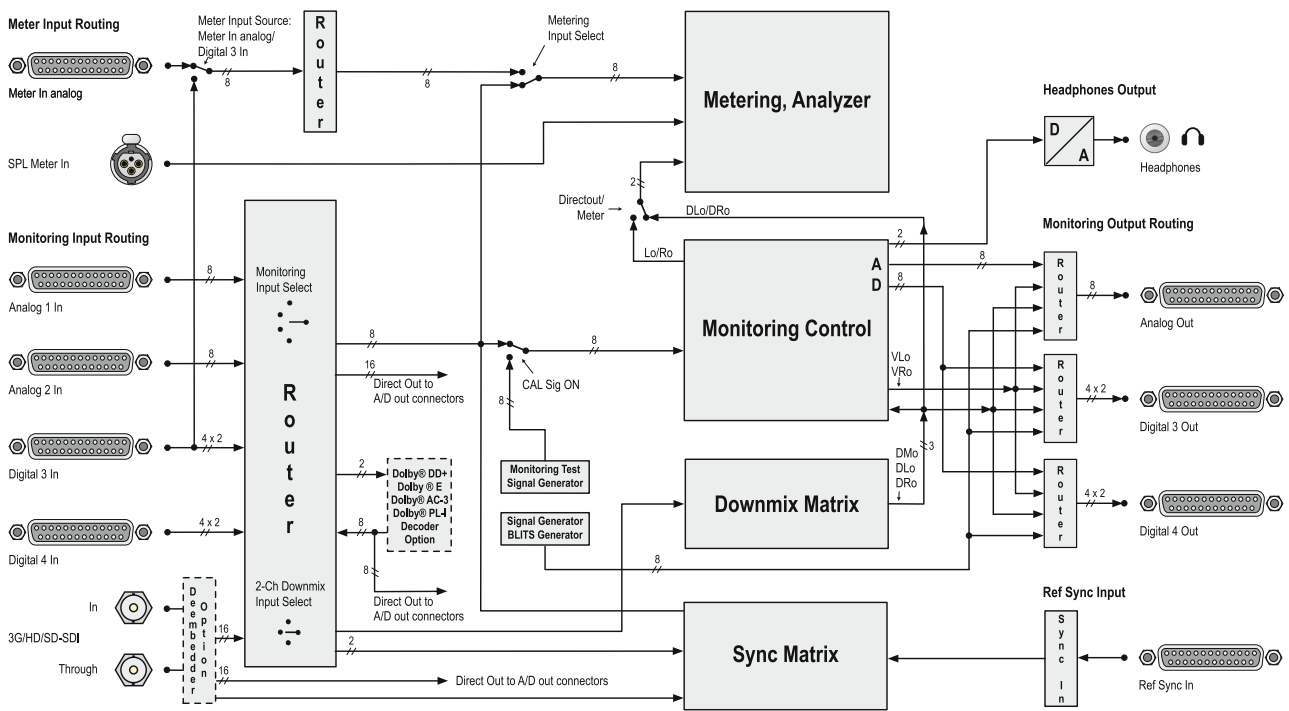

© 05/2013 | Technical changes without prior notice.